



Evaluation Report CCMC 14150-R Clubhouse® Deck

MasterFormat: 06 73 15.06

Evaluation issued: 2020-01-08

1. Opinion

It is the opinion of the Canadian Construction Materials Centre (CCMC) that “Clubhouse® Deck,” when used as exterior decking in accordance with the conditions and limitations stated in Section 3 of this Report, complies with the National Building Code of Canada (NBC) 2015:

- Clause 1.2.1.1.(1)(a) of Division A, using the following applicable acceptable solutions from Division B:
 - Subsection 9.4.2., Specified Loads
 - Article 9.4.2.3., Platforms Subject to Snow and Occupancy Loads
 - Article 9.8.9.1., Loads on Stairs and Ramps
 - Article 9.8.9.6., Finish for Treads and Landings
- Clause 1.2.1.1.(1)(b) of Division A, as an alternative solution that achieves at least the minimum level of performance required by Division B in the areas defined by the objectives and functional statements attributed to the following applicable acceptable solutions:
 - Subsection 9.4.2.1., Applications
 - Article 9.4.3.1., Deflections
 - Article 9.8.9.3., Exterior Wood Steps
 - Article 9.23.15.5., Subfloor Thickness or Rating

This opinion is based on CCMC’s evaluation of the technical evidence in Section 4 provided by the Report Holder.

2. Description

The products are exterior decking planks made of solid-core foamed polyvinyl chloride (PVC) extrusions with an acrylic cap layer. The products are solid- and grooved-edge profile decking boards with nominal dimensions of 139.7 mm wide × 25.4 mm thick. The surface of the products are embossed with a simulated wood-grain pattern and are produced in four different combinations of dual colours (i.e., the top and bottom of the same plank are different colours).

The products are intended to be used as exterior decking to be installed over traditional structural wood framing spaced at 400 mm on centre (o.c.), and stair treads installed on stringers spaced at 230 mm o.c.

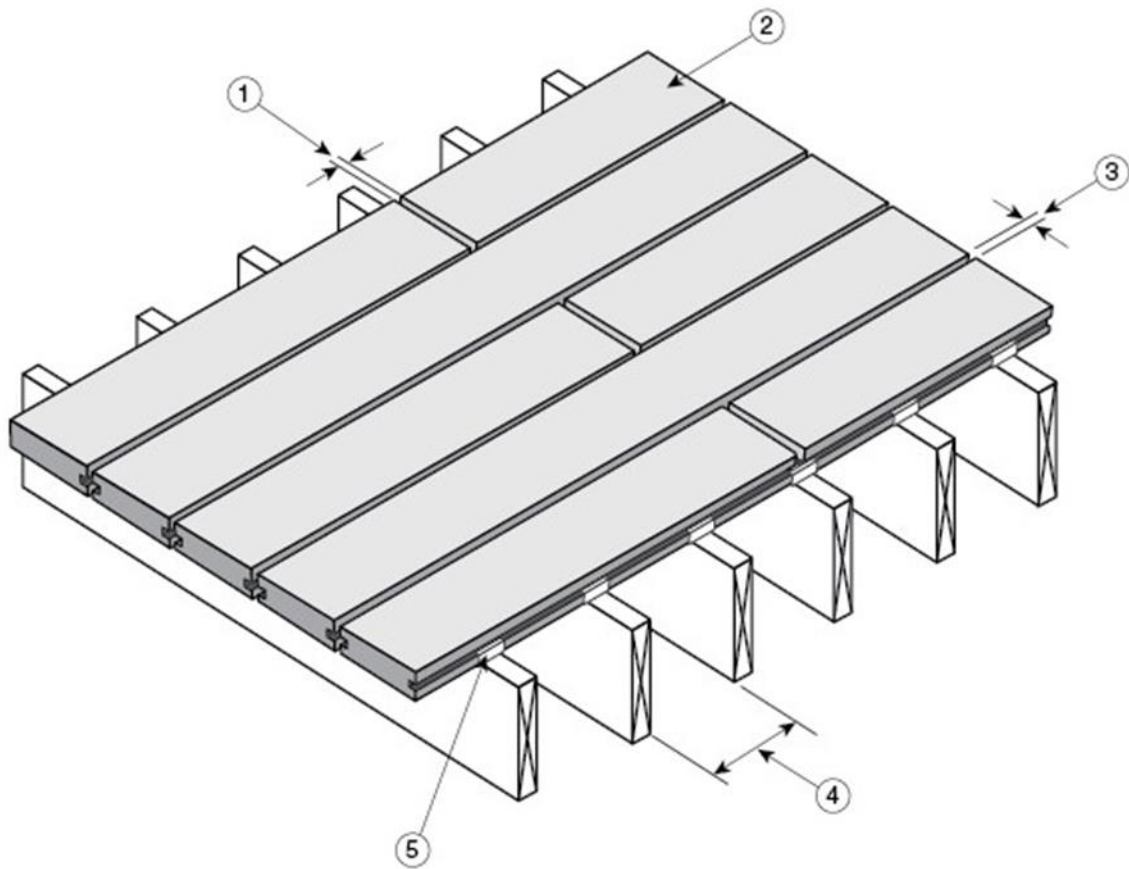

Figure 1. Installation details for the grooved-edge “Clubhouse® Deck” products with hidden fasteners

1. 3 mm minimum end-to-end gapping for installation above 0°C and below 21°C
2. “Clubhouse® Deck” grooved-edge board
3. 3 mm minimum width-to-width gapping
4. maximum joist spacing of 400 mm o.c.
5. hidden fastener or clip system (“EB TY®” or “TigerClaw®”)

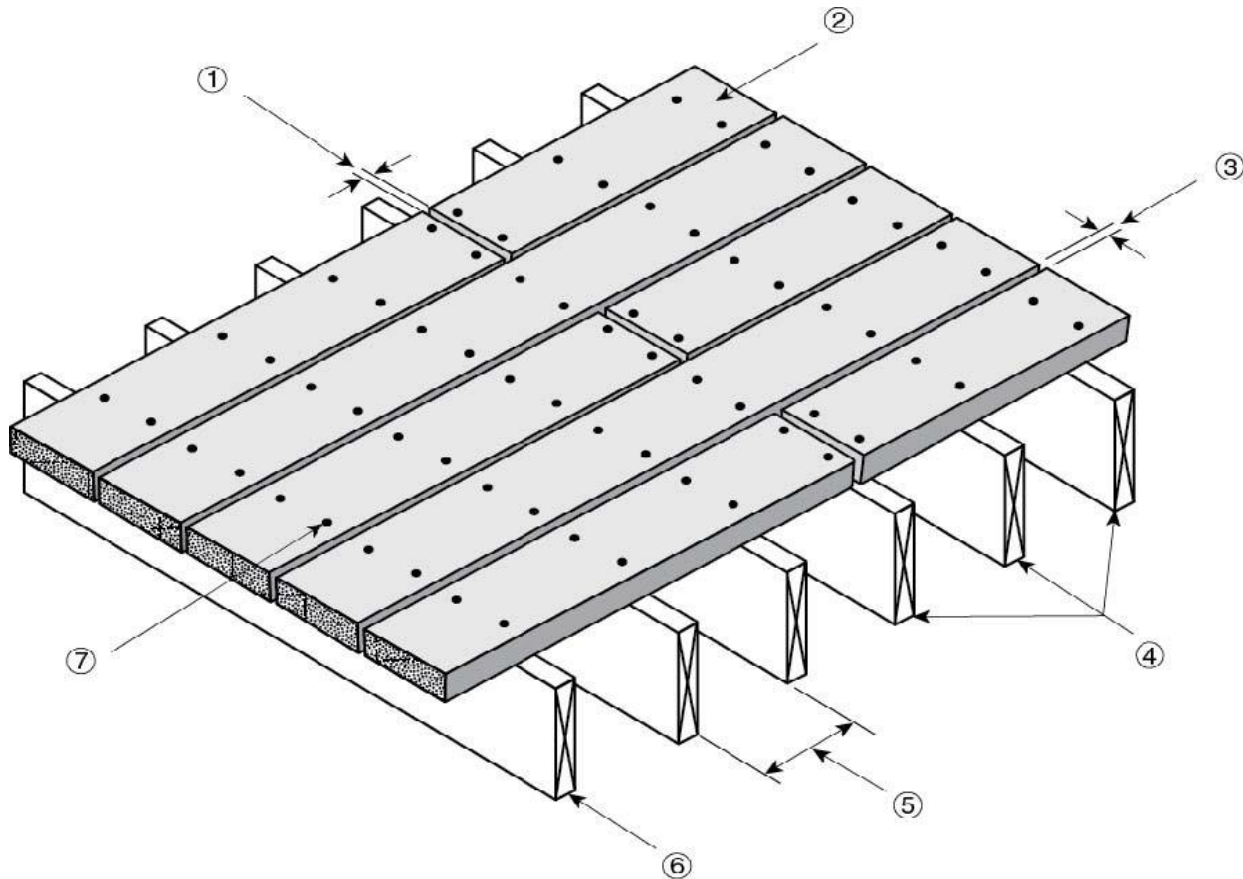

Figure 2. Installation details for the square edge “Clubhouse® Deck” products with exposed fasteners

1. 3 mm minimum end-to-end gapping, for installation above 0°C and below 21°C
2. “Clubhouse® Deck” square edge deck board
3. 3 mm minimum width-to-width gapping
4. minimum of three joists per plank
5. maximum joist spacing of 400 mm o.c.
6. joist designed to support applicable loads
7. two fasteners, 64 mm long, per support

3. Conditions and Limitations

CCMC’s compliance opinion in Section 1 is bound by the products being used in accordance with the conditions and limitations set out below.

- The planks must be installed with supports spaced no greater than 400 mm o.c. Each plank must be supported by at least three supports.
- The products must be fastened to the wood joists with fasteners specified by the manufacturer that conform to Article 9.23.3.1., Standards for Nails and Screws, of Division B of the NBC 2015. The fasteners must have a corrosion-resistant coating or be made of stainless steel. The planks must be fastened with at least two 64-mm-long fasteners per support.

Note: As of January 2004, pressure-treated lumber requires specific hot-dipped galvanized fasteners for satisfactory performance.

- The product must be gapped end to end based upon the length of the plank and the temperature at installation. The end-to-end gapping must be:
 - 3 mm for installations above 0°C and below 21°C
The width-to-width gapping must be:
 - 3 mm for installations above 0°C and below 21°C
- The product must not be installed at temperatures below 0°C.

- The product can be used as stair treads with supports spaced at greater than 230 mm o.c.
- The product is not to be considered as an equivalent to dimensional lumber.
- The products' label or packaging must be identified with the manufacturer's name or logo and the phrase "CCMC 14150-R."

4. Technical Evidence

The Report Holder has submitted technical documentation for CCMC's evaluation. Testing was conducted at laboratories recognized by CCMC. The corresponding technical evidence for this product is summarized below.

4.1 Material Requirements

Table 4.1.1 Results of Testing of Basic Physical and Mechanical Properties of the Products

Property		Unit	Requirement	Result ⁽¹⁾⁽²⁾	
Dimensional change	coefficient of linear expansion (thermal) longitudinal	°C ⁻¹	≤ 2 × 10 ⁻⁵	4.84 × 10 ⁻⁵ (3)	
	coefficient of linear expansion (thermal) cross-sectional			5.05 × 10 ⁻⁵ (3)	
	coefficient of linear expansion (swelling)	%	≤ 0.5, by 80% of specimens	< 0.00	
Strength and stiffness	flexural rigidity (EI)	span-to-depth ratio within 18 to 21	kN·mm ²	> 300 000	269 000 ⁽⁴⁾⁽⁵⁾
	moment capacity (M _R)	span-to-depth ratio within 18 to 21	N·mm	> 190 000	380 000 ⁽⁵⁾
	impact resistance (Gardner test)		%	≤ 50% failure at 10 J	No failure
	creep, recovery and load duration ⁽⁶⁾		%	≤ 25 for creep	9
				≥ 75 for recovery	94
			No failure	Pass	
Strength and stiffness after aging	weathering	impact resistance	%	≥ 75 of non-weathered value	86 ⁽⁷⁾
	accelerated aging	EI	%	≥ 50 of non-aged value	99
		M _R			98
Fastener holding capacity	fastener withdrawal strength (grooved-edge profile) "EB-TY" hidden deck fastener (EBEOA)		N	≥ 600	792
	fastener withdrawal strength (grooved-edge profile) "TigerClaw" TC-G" (Clubhouse connect Clip)				1 460
	fastener withdrawal strength (square-edge profile) "OMG FastenMaster Cortex"				2 757
	lateral fastener strength (grooved-edge profile) "EB-TY" hidden deck fastener (EBEOA)		N	≥ 720	980
	lateral fastener strength (grooved-edge profile) "TigerClaw" TC-G" (Clubhouse connect Clip)				3 050
	lateral fastener strength (square-edge profile) "OMG FastenMaster Cortex"				3 890

Property	Unit	Requirement	Result ⁽¹⁾⁽²⁾
Flame-spread rating	–	≤ 200	70

Notes to Table 4.1.1:

- (1) Average test results of six specimens, except for the “creep, recovery and load duration” results that are from three specimens.
- (2) Test results were obtained to classify the product and are not intended to be used as engineering design properties.
- (3) Performance result allowed based on the manufacturer’s gapping installation instructions. “Clubhouse® Deck” must not be installed at temperatures below 0°C.
- (4) Deemed acceptable based on modulus of elasticity (MoE ≥ 750 MPa) by test results.
- (5) Mean value of test results for solid- and grooved-edge boards.
- (6) Test results for grooved-edge boards.
- (7) Reported average of test results.

4.2 Performance Requirements

Table 4.2.1 Results of Testing of Performance of the Products Under Both Concentrated Static Loads and Impact Loads

Property		Requirement	Result ⁽¹⁾
Concentrated static load	decking at 50°C	≥ 2.45	≥ 4.0
	decking at 20°C		≥ 5.2
	decking at -35°C		≥ 5.2
	decking at 50°C	≤ 2.0	5.6 ⁽²⁾
	decking at 20°C		4.2 ⁽³⁾
	decking at -35°C		3.7 ⁽³⁾
Following impact load of 102 N·m	decking at 50°C	≥ 1.78	no break
		≤ 2.0	3.91 ⁽²⁾

Notes to Table 4.2.1:

- (1) Test results for grooved-edge planks with supports at 400 mm o.c.
- (2) Deemed acceptable. Although this result exceeds the 2.0 mm requirement, the additional deflection is not considered significant for material at 50°C.
- (3) Although this result exceeds the 2.0 mm requirement, the additional deflection is not considered significant based on the product’s test result from creep and creep recovery testing in Table 4.1.1. Therefore, the result is deemed acceptable.

Table 4.2.2 Results of Testing of Durability of the Products

Property	Requirement	Result	
		SPF Lumber	“Clubhouse® Deck”
Bending stiffness	Mean percentage loss in bending stiffness (EI) after ultraviolet (UV) exposure ⁽¹⁾ and accelerated aging ⁽²⁾ must be less than or equal to spruce lumber	8.7%	-1.2%

Property	Requirement	Result	
		SPF Lumber	“Clubhouse® Deck”
Bending strength	Mean percentage loss in moment capacity (M_R) after UV exposure ⁽¹⁾ and accelerated aging ⁽²⁾ must be less than or equal to spruce lumber	32.6%	-1.1%

Notes to Table 4.2.2:

- (1) 4 000 h of Cycle 1 as outlined in Appendix X3.1 of ASTM G 155-13, “Standard Practice for Operating Xenon Arc Light Apparatus for Exposure of Non-Metallic Materials.”
- (2) Five cycles of accelerated aging (wetting, freezing, thawing and drying).

Table 4.2.3 Results of Testing of Performance of the Products Under Concentrated Static Load – Stair Tread

Property		Requirement	Result ⁽¹⁾
Concentrated static load	stair tread	$\geq 5^{(2)}$	18.15
	stair tread nosing	$\geq 5^{(3)}$	12.49
	stair tread	≤ 0.75	0.873 ⁽⁴⁾

Notes to Table 4.2.3:

- (1) Test results are for solid-edge profile planks with stair stringers spaced at 230 mm o.c. at a test condition of 50°C. Three specimens were tested for each test.
- (2) Applied through a 75-mm-diam disk positioned at the centreline of the plank and midway between stringers.
- (3) Applied through a 38-mm-diam disk positioned along the outside edge of the nosing at the stringer location.
- (4) Deemed acceptable as the deflection is still very low at 50°C and the ultimate load is very high as well. Stringer spacing must be at 230 mm o.c.

4.3 Additional Performance Data

Data in this section does not form part of CCMC’s opinion in Section 1.

Table 4.3.1 Additional Performance Data of the Product

Property	Unit	Reference value	Result	
Hardness (11.28-mm-diam ball)	kN	≥ 1.8	3.439	
Slip resistance (longitudinal)	wet condition	slip index	≥ 0.5	1.0
	dry condition			1.0
Slip resistance (transverse)	wet condition	slip index	≥ 0.5	0.86
	dry condition			0.97

Report Holder

TruNorth Composites Inc.
55 Plant Farm Blvd.
Brantford, ON N3S 7W2
Canada

Telephone: 905 265-0022

Email: contactus@clubhousedecking.com

Web site: www.clubhousedecking.com

Plant(s)

Brantford, ON

Disclaimer

This Report is issued by the Canadian Construction Materials Centre, a program of the Construction Research Centre at the National Research Council of Canada. The Report must be read in the context of the entire CCMC Registry of Product Evaluations, including, without limitation, the introduction therein which sets out important information concerning the interpretation and use of CCMC Evaluation Reports.

Readers must confirm that the Report is current and has not been withdrawn or superseded by a later issue. Please refer to http://www.nrc-cnrc.gc.ca/eng/solutions/advisory/ccmc_index.html, or contact the Canadian Construction Materials Centre, Construction Research Centre, National Research Council of Canada, 1200 Montreal Road, Ottawa, Ontario, K1A 0R6. Telephone 613-993-6189. Fax 613-952-0268.

NRC has evaluated the material, product, system or service described herein only for those characteristics stated herein. The information and opinions in this Report are directed to those who have the appropriate degree of experience to use and apply its contents. This Report is provided without representation, warranty, or guarantee of any kind, expressed, or implied, and the National Research Council of Canada (NRC) provides no endorsement for any evaluated material, product, system or service described herein. NRC accepts no responsibility whatsoever arising in any way from any and all use and reliance on the information contained in this Report. NRC is not undertaking to render professional or other services on behalf of any person or entity nor to perform any duty owed by any person or entity to another person or entity.

Date modified:

2020-02-11